

PHYSICS - CET 2026 - VERSION CODE - C2

KEYS

1. An electron falls through a distance 1.5 cm in a uniform electric field of magnitude 2.0×10^4 N/C from rest. The time taken to cover this distance in second is _____ ($e = 1.6 \times 10^{-19}$ C, $m_e = 9.11 \times 10^{-31}$ kg)
- (1) 2.9×10^{-9} (2) 2.9×10^9 (3) 4×10^{-6} (4) 4×10^6

Ans (1)

$$S = \frac{1}{2}at^2$$

$$F_e = ma$$

$$qE = ma \Rightarrow a = \frac{qE}{m}$$

$$S = \frac{1}{2} \left(\frac{qE}{m} \right) t^2$$

$$1.5 \times 10^{-2} = \frac{1}{2} \times \frac{(1.6 \times 10^{-19}) \times 2 \times 10^4}{9.1 \times 10^{-31}} \times t^2$$

$$t^2 \simeq 9 \times 10^{-18}$$

$$t \simeq 3 \times 10^{-9}$$

2. What will be the total electric flux through the faces of the cube as given in the figure with side of length 'a' if a charge Q is placed at B, midpoint of an edge of the cube (see figure)?

(1) $\frac{Q}{8\epsilon_0}$

(2) $\frac{Q}{3\epsilon_0}$

(3) $\frac{Q}{4\epsilon_0}$

(4) $\frac{Q}{2\epsilon_0}$

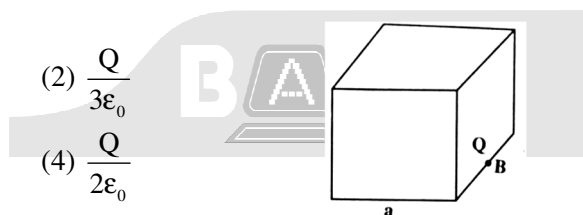

Ans (3)

Charge being at midpoint of edge is not completely enclosed.

So 4 identical cubes must be placed around it.

$$\text{Flux through all the cubes } \phi = \frac{q}{\epsilon_0}$$

$$\text{Flux through each cube } \phi = \frac{1}{4} \frac{q}{\epsilon_0}$$

3. Consider three point charges $-2Q$, Q and $-Q$ and three surfaces S_1 , S_2 and S_3 as shown in the figure. Match the entries of List-I with that of List-II.

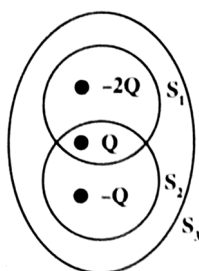

List I		List II	
(a)	Net flux through S_1	(i)	$\frac{-2Q}{\epsilon_0}$
(b)	Net flux through S_2	(ii)	$\frac{-Q}{\epsilon_0}$
(c)	Net flux through S_3	(iii)	Zero

Codes:

(1) (a) – (ii), (b) – (i), (c) – (iii)

(2) (a) – (iii), (b) – (ii), (c) – (i)

(3) (a) – (i), (b) – (ii), (c) – (iii)

(4) (a) – (ii), (b) – (iii), (c) – (i)

Ans (4)

$$\text{Flux through } S_1 \rightarrow \phi_1 = \frac{1}{\epsilon_0} [-2Q + Q] = \frac{-Q}{\epsilon_0}$$

$$\text{Flux through } S_2 \rightarrow \phi_2 = \frac{1}{\epsilon_0} [-Q + Q] = 0$$

$$\text{Flux through } S_3 \rightarrow \phi_3 = \frac{1}{\epsilon_0} [-2Q + Q - Q] = -\frac{2Q}{\epsilon_0}$$

4. A parallel plate capacitor has a uniform electric field 'E' in the space between the plates. If the distance between the plates is 'd' and area of each plate is 'A', the energy stored in the capacitor is

(1) $\frac{1}{2} \epsilon_0 E^2$

(2) $\epsilon_0 EAd$

(3) $\frac{1}{2} \epsilon_0 E^2 Ad$

(4) $\frac{E^2 Ad}{\epsilon_0}$

Ans (3)

5. In the circuit shown in the figure, the potential difference across the $4\mu\text{F}$ capacitor is

(1) 3 V

(2) 4 V

(3) 9 V

(4) 12 V

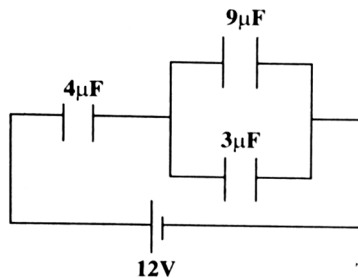

Ans (3)

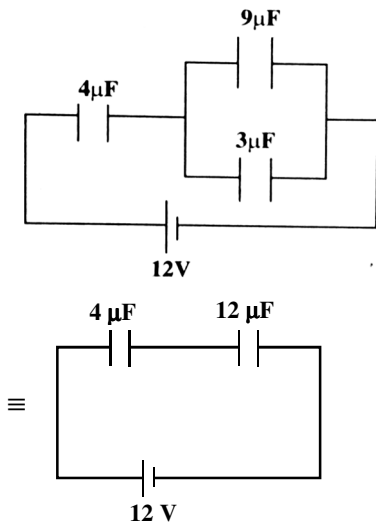

At node B, using KCL

$$I_1 = 1.5 + I_2$$

$$4 = 1.5 + I_2 \Rightarrow I_2 = 2.5 \text{ A}$$

At Node C, using KCL

$$I_2 = 1.5 + I_3$$

$$2.5 = 1.5 + I_3 \Rightarrow I_3 = 1 \text{ A}$$

9. The number of electrons moving per second through the filament of a lamp of 60 W operating at 120 V is nearly ($e = 1.6 \times 10^{-19} \text{ C}$) _____

(1) 6.2×10^{18}

(2) 6.2×10^{19}

(3) 3.1×10^{18}

(4) 3.1×10^{19}

Ans (3)

$$P = 60 \text{ W} \quad V = 120 \text{ V}$$

$$P = VI \Rightarrow I = \frac{P}{V}$$

$$\frac{n \cdot e}{t} = \frac{P}{V}$$

$$\frac{n}{t} = \frac{P}{V \cdot e} = \frac{60}{120 \times 1.6 \times 10^{-19}}$$

$$\frac{n}{t} = 3.1 \times 10^{18} \text{ electrons per second}$$

10. Given below are two statements:

Statement I: The resistivity of a conductor is independent of its temperature.

Statement II: The resistivity of a semiconductor decreases with increase in temperature.

Select the correct option.

(1) Both Statement I and Statement II are false

(2) Both Statement I and Statement II are true

(3) Statement I is true but Statement II is false

(4) Statement I is false but Statement II is true

Ans (4)

Statement I is false but statement II is true

11. Current flowing through a wire decreases linearly from 10 A to zero in 4 s shown in the graph. Find the total charge flowing through the wire in the given time interval.

(1) 40 C

(2) 20 C

(3) 10 C

(4) 80 C

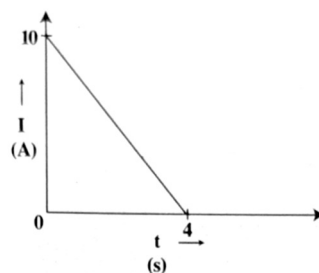

Ans (2)

Total area under I v/s t graph represents net charge

$$\Delta q = \frac{1}{2} \times 4 \times 10 = 20 \text{ C}$$

12. In a conducting region, 10^{19} electrons and 10^{19} protons move to the left, while 10^{19} α -particles move to the right per second. The resulting electric current is ($e = 1.6 \times 10^{-19}$ C) _____
- (1) 3.2 A towards left (2) 3.2 A towards right
 (3) 1.6 A towards left (4) 1.6 A towards right

Ans (2)

$$I = \frac{q_{\text{net}}}{t} = \frac{[-10^{19}e + 10^{19}e + 10^{19}(2e)]}{1}$$

$$I = 2 \times 10^{19} \times 1.6 \times 10^{-19} = 3.2 \text{ A towards right}$$

13. A point charge is placed in a moving train. A passenger A sitting in the train and person B on the ground observe the fields due to this charge. Then
- (1) A observes both electric and magnetic fields
 (2) B observes both electric and magnetic fields
 (3) A observes only magnetic field
 (4) B observes only electric field

Ans (2)

For observer A, charge is at rest, hence he observer's only electric field.

Where as for person B, charge is in motion, hence he observes both electric and magnetic fields.

14. A proton, an electron and an α -particle enter at right angles to a uniform magnetic field with the same velocity. If R_p , R_e and R_α are the radii of circular paths of these particles, then
- (1) $R_\alpha = R_p = R_e$ (2) $R_\alpha > R_p > R_e$ (3) $R_\alpha < R_p < R_e$ (4) $R_\alpha > R_p = R_e$

Ans (2)

$$r = \frac{mv}{qB} \text{ here, } v \text{ and } B \text{ are constant so, } r \propto \frac{m}{q}$$

$$\text{For proton, } R_p \propto \frac{m_p}{q_p}$$

$$\text{For electron } R_e \propto \frac{m_e}{q_e}$$

$$\text{For } \alpha\text{-particle } R_\alpha \propto \frac{m_\alpha}{q_\alpha} \propto \frac{4m_p}{2q_p} \propto \frac{2m_p}{q_p}$$

$$\therefore R_\alpha > R_p > R_e$$

15. Biot-Savart law indicates that an electron moving with a velocity \vec{V} produces a magnetic field \vec{B} around it such that
- (1) \vec{B} is parallel to \vec{V} (2) \vec{B} is perpendicular to \vec{V}
 (3) \vec{B} is anti-parallel to \vec{V} (4) \vec{B} is inclined to \vec{V} by 45°

Ans (2)

16. Two identical circular current loops carrying equal currents are placed with their axes inclined at 45° to each other as shown in the figure. The resultant magnetic field at P is

- (1) $\frac{\mu_0 I}{16\sqrt{2}R} [(\sqrt{2}+1)\hat{i} + \hat{j}]$
- (2) $\frac{\mu_0 I}{16\sqrt{2}R} [\sqrt{2}\hat{i} + \hat{j}]$
- (3) $\frac{\mu_0 I}{16R} [(\sqrt{2}+1)\hat{i} + \hat{j}]$
- (4) $\frac{\mu_0 I}{16R} [\sqrt{2}\hat{i} + \hat{j}]$

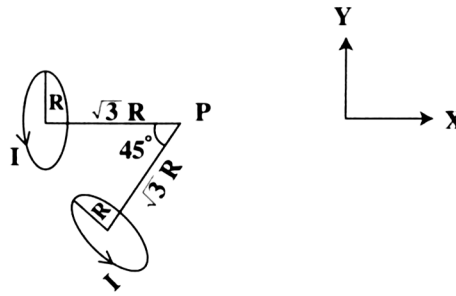

Ans (1)

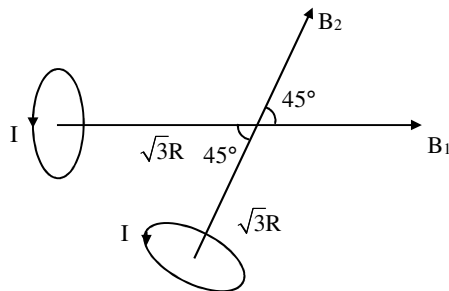

$$|\vec{B}_1| = |\vec{B}_2| = \frac{\mu_0}{4\pi} \cdot \frac{2\pi \cdot I R^2}{(R^2 + x^2)^{3/2}}$$

$$= \frac{\mu_0}{2} \cdot \frac{I R^2}{8R^3} = \frac{\mu_0 I}{16R}$$

$$\vec{B}_1 = \frac{\mu_0 I}{16R} \hat{i}$$

$$\vec{B}_2 = B_2 \cos 45^\circ \hat{i} + B_2 \sin 45^\circ \hat{j}$$

$$= \frac{\mu_0 I}{16R} \cdot \frac{1}{\sqrt{2}} \hat{i} + \frac{\mu_0 I}{16R} \cdot \frac{1}{\sqrt{2}} \hat{j}$$

$$\vec{B}_R = \vec{B}_1 + \vec{B}_2 = \frac{\mu_0 I}{16\pi} \left[\left(\frac{1}{\sqrt{2}} + 1 \right) \hat{i} + \frac{1}{\sqrt{2}} \hat{j} \right]$$

$$\vec{B} = \frac{\mu_0 I}{16\sqrt{2}R} [(\sqrt{2}+1)\hat{i} + \hat{j}]$$

$$x = \sqrt{3}R$$

$$(R^2 + x^2)^{3/2} = (R^2 + 3R^2)^{3/2}$$

$$= [(2R)^2]^{3/2} = 8R^3$$

17. If a paramagnetic bar is brought near a bar magnet, then it is

- (1) Attracted by both the poles of the bar magnet
- (2) Repelled by both the poles of the bar magnet
- (3) Attracted by the South-pole and repelled by the North-pole of the bar magnet
- (4) Attracted by the North-pole and repelled by the South-pole of the bar magnet

Ans (2)

Attracted by both poles near a bar magnet

18. Pick out the WRONG statements about magnetic substances

(χ = magnetic susceptibility) (μ_r = relative permeability).

- I. Substances with $-1 \leq \chi < 0$ are diamagnetic
- II. Substances with $\chi \gg 1$ are paramagnetic
- III. Substances with $\chi \ll 1$ are ferromagnetic
- IV. Substances with $\mu_r \gg 1$ are ferromagnetic

- (1) I and II (2) III and IV (3) II and III (4) II and IV

Ans (3)

19. Work function of the metal is

- (1) Maximum possible energy acquired by an electron
- (2) Equal for all metals
- (3) Minimum energy required by an electron to just eject from metal surface
- (4) Maximum energy which is given to electron to move out of metal surface

Ans (3)

20. Variation of photoelectric current with anode potential is shown below. Choose the correct option (V_0 = stopping potential)

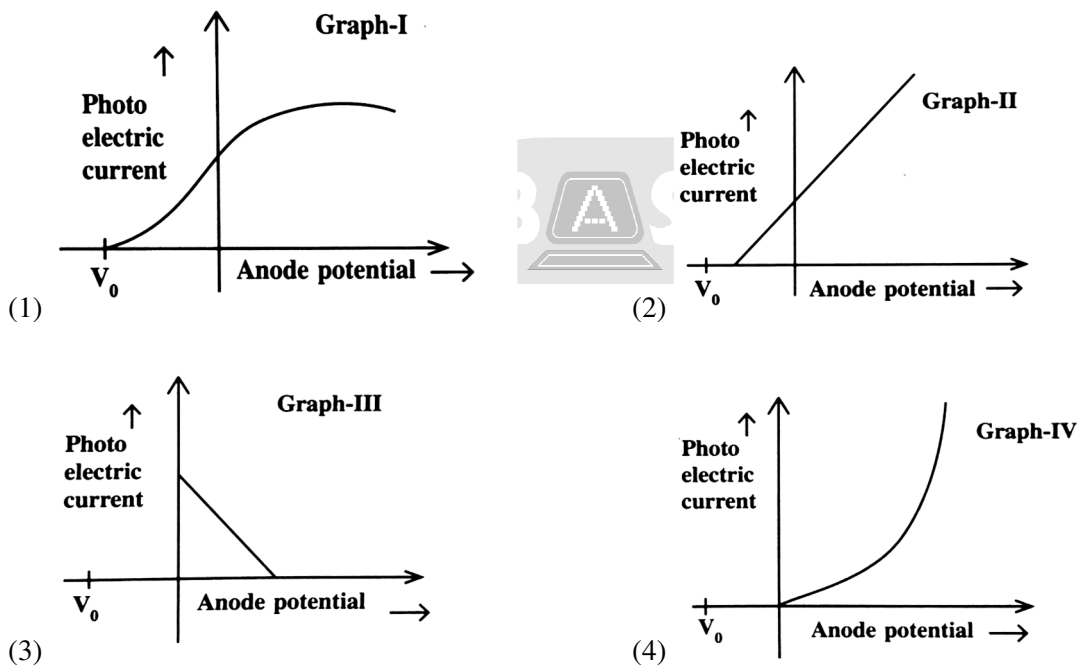

Ans (1)

21. In a Faraday-Henry's experiment, a coil is connected to a galvanometer. For the deflection of pointer in the galvanometer, which of the following statement/s is/are WRONG? The pointer in the galvanometer deflects -

- (a) When the bar magnet is moved towards the stationary coil along its axis
- (b) When the bar magnet is moved away from the stationary coil along its axis
- (c) When the coil is moved towards the stationary bar magnet along its axis
- (d) When the coil and the magnet are moved without relative motion between them

- (1) a and b (2) b and c (3) a, b and c (4) only d

Ans (4)

Emf induces only when there is relative motion between coil and magnet.

22. In the figure shown, the conductor PQ of length l is moved from $x = 0$ to $x = b$ and then up to $x = 2b$ with constant velocity \vec{v} . A uniform magnetic field \vec{B} is perpendicular to the plane of the paper and extends from $x = 0$ to $x = b$ and it is zero from $x > b$. The magnitude of emf induced in the conductor is

- (1) $B l x ; 0 \leq x < b$
 (2) Zero ; $0 \leq x < b$
 (3) $B l v ; 0 \leq x \leq b$
 (4) $B l v ; b \leq x < 2b$

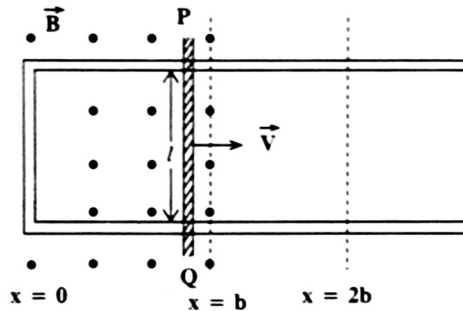
**Ans (3)**

Conceptual: Motion emf

23. In a circuit containing a pure resistor connected to an AC source,
 (1) Voltage leads the current by 90°
 (2) Current leads the voltage by 90°
 (3) Voltage and current are in same phase with each other
 (4) Current leads the voltage by 180°

Ans (3)

Voltage and current are in same phase

Conceptual

24. A light bulb rated 100 W is connected to an AC source of 220 V, 50 Hz. The rms current through the bulb is
 (1) 0.454 A (2) 0.545 A (3) 2.20 A (4) 0.22 A

Ans (1)

$$P = V_{\text{rms}} I_{\text{rms}} \cos \phi$$

For pure resistor $\cos \phi = 1$

$$100 = 220 I_{\text{rms}}$$

$$I_{\text{rms}} = \frac{100}{220} = 0.454 \text{ A}$$

25. A small town with a demand of 900 kW of electric power at 220 V is situated 20 km away from an electric power generating station. The two-wires line has resistance per unit length of $5 \times 10^{-4} \Omega \text{m}^{-1}$. The town gets power from the line through 45000 V to 220 V stepdown transformer at a substation in the town. The line power loss in the form of heat is
 (1) 4 kW (2) 8 kW (3) 40 kW (4) 80 kW

Ans (2)

$$R_c = 5 \times 10^{-4} \times 20 \times 10^3 \times 2$$

$$R_c = 20 \Omega$$

Power loss in wire

$$P_c = \frac{P^2 R_c}{V_c^2}$$

$$= \frac{(9 \times 10^5)^2 \times 20}{(4.5 \times 10^4)^2} = 80 \times 10^2$$

$$P_c = 8 \times 10^3 = 8 \text{ kW}$$

26. Match the following Maxwell's equations:

(The symbols used here have their usual meanings)

List I		List II	
(a)	Gauss' law for electrostatics	(i)	$\oint \vec{E} \cdot d\vec{A} = \frac{Q}{\epsilon_0}$
(b)	Gauss' law for magnetism	(ii)	$\oint \vec{B} \cdot d\vec{l} = \mu_0 \left[i_c + \epsilon_0 \frac{d\phi_E}{dt} \right]$
(c)	Faraday's law	(iii)	$\oint \vec{B} \cdot d\vec{A} = 0$
(d)	Ampere-Maxell's law	(iv)	$\oint \vec{E} \cdot d\vec{l} = -\frac{d\phi_B}{dt}$

(1) (a) - (i); (b) - (iii); (c) - (iv), d - (ii)

(2) (a) - (ii); (b) - (iii); (c) - (i), d - (iv)

(3) (a) - (i); (b) - (ii); (c) - (iii), d - (iv)

(4) (a) - (ii); (b) - (iii); (c) - (iv), d - (i)

Ans (1)

Conceptual

27. With reference to the figure shown below, match the following

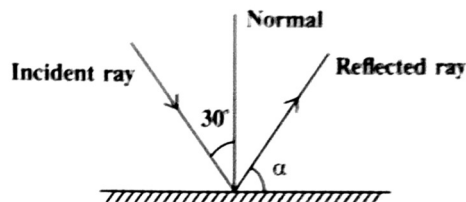

List I		List II	
(a)	Angle of reflection	(i)	60°
(b)	Value of α	(ii)	120°
(c)	Angle of deviation	(iii)	30°

(1) (a) - (i); (b) - (ii); (c) - (iii)

(2) (a) - (ii); (b) - (i); (c) - (iii)

(3) (a) - (iii); (b) - (i); (c) - (ii)

(4) (a) - (iii); (b) - (ii); (c) - (i)

Ans (3)

$$r = i = 30^\circ$$

$$\alpha = 90^\circ - r = 90^\circ - 30^\circ = 60^\circ$$

$$d = 180^\circ - 2i = 180^\circ - 2 \times 30^\circ = 120^\circ$$

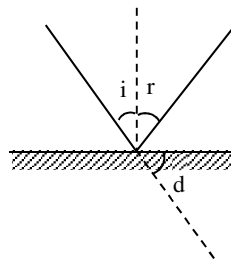

$$\frac{5\lambda}{2} \sin \theta = n\lambda$$

$$\sin \theta = n \frac{2}{5}$$

But $\sin \theta < 1$ $\therefore n < 2.5$

$\therefore n$ can be $-2, -1, 0, 1, 2$

Five maxima can be observed

33. The radius of first orbit in hydrogen atom is 5.3×10^{-11} m. The kinetic energy E_K , potential energy E_P and total energy E_T of electron in first orbit are

- (1) $E_K = -13.6$ eV, $E_P = 27.2$ eV, $E_T = 13.6$ eV
- (2) $E_K = 13.6$ eV, $E_P = -27.2$ eV, $E_T = -13.6$ eV
- (3) $E_K = -27.2$ eV, $E_P = -13.6$ eV, $E_T = 13.6$ eV
- (4) $E_K = 13.6$ eV, $E_P = -6.8$ eV, $E_T = -13.6$ eV

Ans (2)

For 1st orbit of hydrogen atom

$$E_T = -13.6 \text{ eV}$$

$$E_K = -E_T = -\frac{E_P}{2}$$

$$\therefore E_K = 13.6 \text{ eV}$$

$$E_P = -27.2 \text{ eV}$$

34. Bohr's second postulate implies quantisation of

- (1) Charge of an electron
- (2) Energy of an electron
- (3) Angular momentum of electron
- (4) Radiated energy by an electron

Ans (3)

$$\text{Bohr's quantisation condition} = mvr = \frac{nh}{2\pi}$$

$$= L = \frac{nh}{2\pi}$$

\therefore Angular momentum of electron is quantised

35. An electron transition takes place from excited state to ground state in hydrogen atom, then

- (1) Its kinetic energy increases but potential energy and total energy decrease
- (2) Its kinetic energy, potential energy and total energy decrease
- (3) Kinetic energy decreases, potential energy increases but total energy remains same
- (4) Kinetic energy and total energy decrease but potential energy increases

Ans (1)

From the relation

$$K = -T = -\frac{U}{2}$$

Since electron transition takes place from excited state to ground state total energy further decreases, potential energy also decreases but kinetic energy increases.

36. An n-type and p-type semiconductor can be obtained by respectively doping pure silicon with

- (1) Arsenic and Phosphorous respectively
- (2) Indium and Aluminium respectively
- (3) Phosphorous and Indium respectively
- (4) Aluminium and Boron respectively

Ans (3)

To dope a semiconductor to n-type, pentavalent impurities must be used like Phosphorous, Arsenic, Antimony

To dope a semiconductor to p-type, trivalent impurities must be used like Boron, Indium, Aluminium, Gallium

37. In which of the following figures, diode is reverse biased?

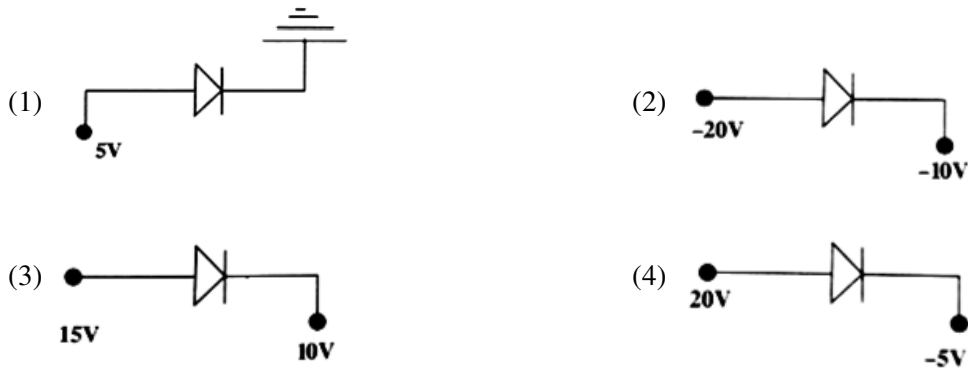

Ans (2)

Circuit (1) \Rightarrow p side is at higher potential, N is at lower potential \therefore diode is forward biased

Circuit (2) \Rightarrow p side is at lower potential, N is at higher potential \therefore diode is reversed biased

Circuit (3) \Rightarrow p side is at higher potential, N is at lower potential \therefore diode is forward biased

Circuit (4) \Rightarrow p side is at higher potential, N is at lower potential \therefore diode is forward biased

38. A wafer of pure germanium crystal has two parts X and Y. The end X is obtained by doping with arsenic and Y with indium. It is connected to a battery as shown in the figure. Which of the following statements is correct?

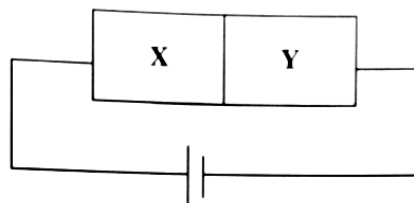

(1) X is p-type, Y is n-type and the junction is forward biased

(2) X is n-type, Y is p-type and the junction is forward biased

(3) X is p-type, Y is n-type and the junction is reverse biased

(4) X is n-type, Y is p-type and the junction is reverse biased

Ans (4)

To dope a semiconductor to n-type, pentavalent impurities must be used like Phosphorous, Arsenic, Antimony

To dope a semiconductor to p-type, trivalent impurities must be used like Boron, Indium, Aluminium, Gallium

\therefore x is n-type and y is p-type, the positive terminal of the battery is connected to n side of the semiconductor
Therefore, the diode is reversed biased.

39. From the graph of angle of deviation versus angle of incidence for an equilateral prism, the refractive index of material of prism is

- (1) $\frac{\sqrt{3}}{2}$
- (2) $\frac{3}{2}$
- (3) $\sqrt{3}$
- (4) $\sqrt{2}$

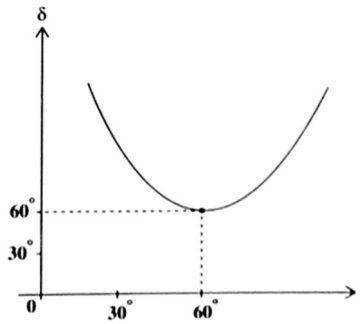

Ans (3)

$$\eta = \frac{\sin\left(\frac{A+D}{2}\right)}{\sin\left(\frac{A}{2}\right)}$$

$$\eta = \frac{\sin\left(\frac{60^\circ + 60^\circ}{2}\right)}{\sin\left(\frac{60^\circ}{2}\right)} = \frac{\sin\left(\frac{120^\circ}{2}\right)}{\sin(30^\circ)} = \frac{\sin 60^\circ}{\sin 30^\circ} = \frac{\frac{\sqrt{3}}{2}}{\frac{1}{2}} = \frac{\sqrt{3}}{1}$$

40. Which of the following circuits is correct for verification of Ohm's law?

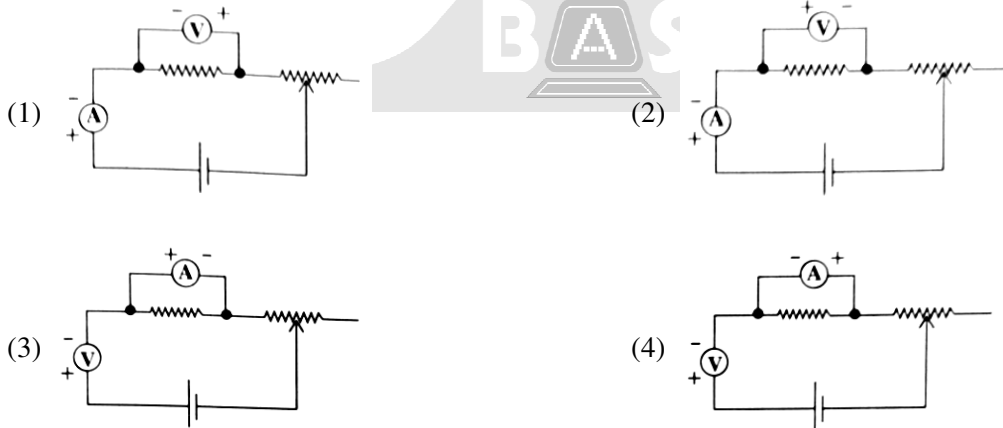

Ans (2)

41. Match the physical quantities given in List-I with dimensions expressed in terms of mass (M), length (L), time (T) and electric current (A) given in List-II.

List-I		List-II	
(a)	Torque	(i)	$[M^{-1} L^{-2} T^4 A^2]$
(b)	Gravitational constant	(ii)	$[M^1 L^2 T^{-1}]$
(c)	Capacitance	(iii)	$[M^{-1} L^3 T^{-2}]$
(d)	Planck's constant	(iv)	$[M^1 L^2 T^{-2}]$

Codes:

(1) (a)-(iv), (b)-(ii), (c)-(iii), (d)-(i)

(2) (a)-(iv), (b)-(iii), (c)-(i), (d)-(ii)

(3) (a)-(iv), (b)-(i), (c)-(iii), (d)-(ii)

(4) (a)-(ii), (b)-(i), (c)-(iii), (d)-(iv)

Ans (2)

Torque = F.d

$$= (\text{MLT}^{-2}) [\text{L}]$$

$$= \text{ML}^2 \text{T}^{-2}$$

$$G = \frac{Fd^2}{M^2} = \frac{[\text{MLT}^{-2}] \text{L}^2}{\text{M}^2}$$

$$= [\text{M}^{-1} \text{L}^3 \text{T}^{-2}]$$

$$h = \frac{E}{v} = \frac{\text{ML}^2 \text{T}^{-2}}{[\text{T}^{-1}]}$$

$$= [\text{ML}^2 \text{T}^{-1}]$$

$$C = \frac{Q}{V} = \frac{Q}{\frac{W}{Q}} = \frac{Q^2}{W}$$

$$= \frac{[\text{AT}]^2}{\text{ML}^2 \text{T}^{-2}} = [\text{M}^{-1} \text{L}^{-2} \text{T}^4 \text{A}^2]$$

42. A car covers the first half of the distance between two places at 40 km/h and another half at 50 km/h. The average speed of the car is

(1) 45.00 km/h

(2) 44.44 km/h

(3) 43.14 km/h

(4) 42.04 km/h

Ans (2)

$$V_{\text{av}} = \frac{2V_1V_2}{V_1 + V_2} = \frac{2(40)(50)}{40 + 50} = 44.4 \text{ Km hr}^{-1}$$

43. Two bodies are projected with the same velocity. If one is projected at an angle of 30° and the other at 45° to the horizontal, then the ratio of maximum heights attained is

(1) 3:1

(2) 1:2

(3) 4:1

(4) 1:3

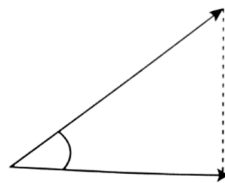
**Ans (2)**

$$H = \frac{u^2 \sin^2 \phi}{2g}$$

$$H \propto \sin^2 \theta$$

$$\frac{H_1}{H_2} = \left(\frac{\sin 30^\circ}{\sin 45^\circ} \right)^2 = \left(\frac{\frac{1}{2}}{\frac{1}{\sqrt{2}}} \right)^2 = \left(\frac{1}{\sqrt{2}} \right)^2$$

$$= \frac{1}{2}$$

44. The velocity of a particle moving along x-axis is given as $V = x^2 - 5x + 4$ (in m/s) where x denotes the x-coordinate of the particle in metres. The magnitude of the acceleration of the particle when the velocity of the particle zero is

- (1) 2 m/s^2 (2) 3 m/s^2 (3) Zero (4) 1 m/s^2

Ans (3)

$$\begin{aligned} V &= x^2 - 5x + 4 = 0 \\ &= x^2 - 4x - x + 4 = 0 \\ &= (x - 4)(x - 1) = 0 \\ &= x = 4 \text{ or } 1 \end{aligned}$$

$$V = x^2 - 5x + 4$$

$$\frac{dV}{dx} = 2x - 5$$

$$a = \frac{dV}{dt} = \frac{dV}{dx} \times \left(\frac{dx}{dt} \right)$$

$$a = v \cdot \frac{dV}{dx} = (x^2 - 5x + 4)(2x - 5)$$

When $x = 1$ or 4 $a = 0$

45. A man weighs 80 kg. He stands on a weighing scale in a lift which is moving upwards with a uniform acceleration of 6 m/s^2 . What would be his weight in kg? ($g = 10 \text{ m/s}^2$)

- (1) Zero (2) 48 kg (3) 120 kg (4) 128 kg

Ans (4)

$$\begin{aligned} F &= m(g + a) \\ &= 80(10 + 6) \\ &= 80 \times 16 \\ &= 1280 \text{ N} \end{aligned}$$

$\therefore m = 128 \text{ kg}$

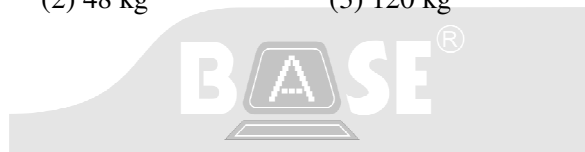

46. A mass M is hung with a light inextensible string as shown in figure. Find the tension of the horizontal string.

- (1) $\sqrt{2} Mg$
 (2) $\sqrt{3} Mg$
 (3) Mg
 (4) $3 Mg$

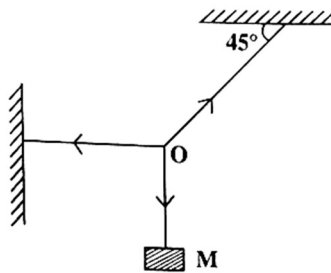

Ans (3)

$$T_1 \cos 45^\circ = Mg$$

$$T_1 \times \frac{1}{\sqrt{2}} = mg$$

$$T_1 = \sqrt{2} mg$$

$$T_2 = T_1 \sin 45^\circ$$

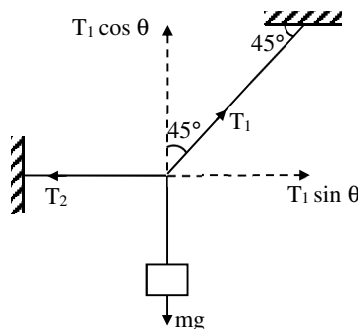

$$T_2 = \sqrt{2} mg \frac{1}{\sqrt{2}}$$

$$T_2 = mg$$

47. Two bodies with kinetic energies in the ratio of 3:1 are moving with equal linear momentum. The ratio of their masses is

(1) 1:4

(2) 1:3

(3) 1:2

(4) 1:1

Ans (2)

$$\frac{K.E_1}{K.E_2} = \frac{3}{1}$$

$$\frac{\frac{P^2}{2m_1}}{\frac{P^2}{2m_2}} = \frac{3}{1}$$

$$\frac{m_2}{m_1} = \frac{3}{1} \quad \frac{m_1}{m_2} = \frac{1}{3}$$

48. A horizontal force of 5 N is applied on a stationary body of mass 5 kg, which is initially at rest on a frictionless table. The change in kinetic energy of the body in 10 s is

(1) 25 J

(2) Zero

(3) 125 J

(4) 250 J

Ans (4)

$$v = u + at$$

$$v = 0 + \left(\frac{F}{m}\right)t$$

$$v = 0 + \frac{5}{5} \times 10 = 10 \text{ m s}^{-1}$$

$$\Delta k = \frac{1}{2}mv^2$$

$$= \frac{1}{2} \times 5 \times 10^2 = 25 \text{ J}$$

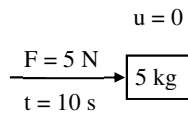

49. The angular momentum of a moving body remains constant, if

(1) net external force is applied

(2) net pressure is applied

(3) net external torque is applied

(4) net external torque is not applied

Ans (4)

50. If the earth were to suddenly contract to half of its present radius, what would be the duration of the day?

(1) 6 h

(2) 18 h

(3) 24 h

(4) 30 h

Ans (1)

$$R' = \frac{R}{2}$$

$$I_1\omega_1 = I_2\omega_2$$

$$\frac{2}{5}(mR^2)\omega_1 = \frac{2}{5}M\left(\frac{R}{2}\right)^2\omega_2$$

$$I\omega_2 = \frac{1}{4}I\omega_1$$

$$\Rightarrow \omega_2 = 4\omega_1$$

$$\frac{2\pi}{T_2} = 4\left(\frac{2\pi}{T_1}\right)$$

$$T_2 = \frac{T_1}{4} = \frac{24}{4} = 6\text{h}$$

51. Imagine a new planet having the same density as that of the earth, but it is two times bigger than the earth in size. If the acceleration due to gravity on the surface of the earth is g and that on the surface of the new planet is g' , then

- (1) $g' = \frac{g}{4}$ (2) $g' = 8g$ (3) $g' = 2g$ (4) $g' = 4g$

Ans (3)

$$\rho_P = \rho_E$$

$$R_P = 2R_E$$

$$g'_P = ?$$

$$g = \frac{GM}{R^2} = \frac{G \frac{4}{3} \pi R^3 \rho}{R^2}$$

$$g = \frac{4}{3} \pi G \rho R$$

$$\frac{g'}{g} = \frac{2R}{R}$$

$$g' = 2g$$

52. Suppose the acceleration due to gravity at the earth's surface is $g \text{ m/s}^2$ and at the surface of moon it is $g' \text{ m/s}^2$. An $M \text{ kg}$ passenger goes from the earth to the moon in a spaceship moving with a constant velocity (Neglect all other objects in the sky). Which curve best represents the weight (net gravitational force) as a function of time?

- (1) A
(2) B
(3) C
(4) D

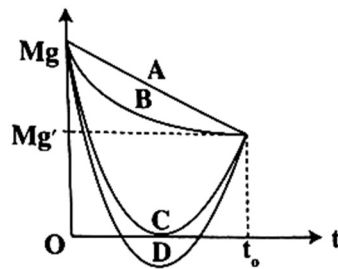

Ans (3)

53. Instrument fitted in the carburetor of the automobile to provide the correct mixture of air and fuel necessary for combustion works on

- (1) Pascal's Law (2) Bernoulli's Principle
(3) Newton's Law of Cooling (4) Archimedes' Principle

Ans (2)

54. There are two wires of same material and same length while the diameter of second wire is two times the diameter of the first wire. Then the ratio of extensions produced in the wires by applying same load will be

- (1) 1:1 (2) 1:2 (3) 2:1 (4) 4:1

Ans (4)

$$d_2 = 2d_1$$

$$r_2 = 2r_1$$

$$Y = \frac{\frac{F}{A}}{\frac{\Delta L}{L}} = \frac{FL}{A \Delta L}$$

$$\Delta L = \frac{FL}{AY}$$

$$\Delta L \propto \frac{1}{A} \propto \frac{1}{r^2} \propto \frac{1}{d^2}$$

$$\frac{\Delta L_1}{\Delta L_2} = \left(\frac{d_2}{d_1}\right)^2 = \left(\frac{2d_1}{d_1}\right)^2 = 4$$

55. In a capillary tube experiment, a vertical 30 cm long capillary tube is dipped in water, water rises upto a height of 10 cm due to capillarity. If this experiment is conducted in a freely falling water in an elevator, then the length of the water column becomes

- (1) 10 cm (2) 20 cm (3) 30 cm (4) Zero

Ans (3)

$$h = \frac{2T \cos \theta}{r\rho g}$$

As $g_{\text{eff}} \rightarrow 0$, $h \rightarrow \infty$

So, liquid will try to rise to an infinite height. But liquid cannot rise beyond the actual length of the tube.

So $l = 30$ cm

56. In thermodynamic processes, which of the following statements is not true?

- (1) In an isothermal process, the temperature remains constant
 (2) In an isobaric process, the volume remains constant
 (3) In an adiabatic process, the system is insulated from the surroundings
 (4) In an adiabatic process, $PV^\gamma = \text{a constant}$

Ans (2)

In an isobaric process, the pressure remains constant.

57. The graph of pressure P and volume V of 1 mole of an ideal gas at constant temperature is

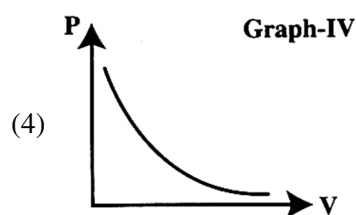
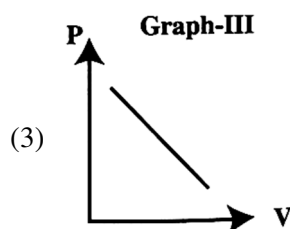
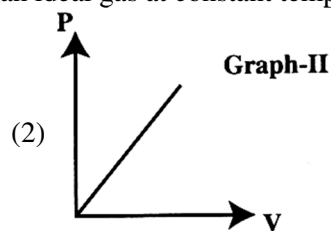
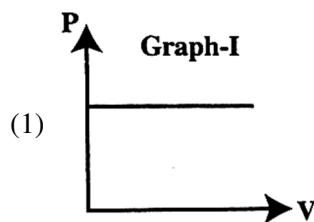

Ans (4)

$$PV = RT \text{ for } n = 1$$

$$PV = \text{constant}$$

$$P \propto \frac{1}{V}$$

Graph should be rectangular hyperbola which is shown in option (4).

58. A mass of 1 kg is executing SHM. Its displacement is given by $x = 6.0 \cos\left(100t + \frac{\pi}{4}\right)$ cm What is the maximum kinetic energy?

- (1) 3 J (2) 6 J (3) 9 J (4) 18 J

Ans (4)

$$x = 6.0 \cos\left(100t + \frac{\pi}{4}\right) \text{ cm}$$

$$\begin{aligned} v_{\max} &= A\omega \\ &= 0.06 \times 100 \\ &= 6 \text{ m s}^{-1} \end{aligned}$$

$$KE_{\max} = \frac{1}{2}mv_{\max}^2 = \frac{1}{2} \times 1 \times (6)^2 = 18 \text{ J}$$

59. A source of frequency ν gives 6 beats/second when sounded with a source of frequency 200 Hz. The second Harmonic of frequency 2ν of the source gives 8 beats/second when sounded with a source of frequency 420 Hz. The value of ν is

- (1) 205 Hz (2) 206 Hz (3) 195 Hz (4) 210 Hz

Ans (2)

Condition I

$$\nu = 200 + 6 = 206 \text{ Hz}$$

$$\nu = 200 - 6 = 194 \text{ Hz}$$

Condition II

$$|2\nu - 420| = 8$$

$$|2 \times 206 - 420| = 8$$

$$|412 - 420| = 8$$

So option (2) is correct.

60. Following are statements of a few processes taking place in nature.

I. Free expansion of a gas

II. The combustion of a mixture of petrol and air ignited by a spark

III. The leaking of gas from the kitchen cylinder

IV. The transfer of heat from one heated part of a liquid to the other colder part

Which amongst these processes are irreversible in nature?

- (1) I and II (2) III and IV (3) II, III and IV (4) I, II, III and IV

Ans (4)

* * *